

Installation Manual

TP15KC

Parts Check List

Notes about your **TP15KC** lift

Installation Instructions

- Step 1** Measure lift area and check for defects
- Step 2** Cylinder assembly
- Step 3** Position columns and uprights, level columns and install top beam
- Step 4** Install anchor bolts and re-level columns
- Step 5** Install and adjust cables
- Step 6** Install power unit, hoses and cut-off cable
- Step 7** Install arms
- Step 8** Install spinup pads and check height adapters
- Step 9** Electrical hook-up
- Step 10** Test and adjust lift

Operation

Learn proper operation and recheck lift components

Maintenance Schedule

Please read and follow maintenance guide

Troubleshooting Guide

Installation Manual

TP15KC

Parts check list

IN COLUMN-

2 40'8"x 3/8" cables with four nuts and washers

2 3"x 36" pistons with rollers

ON TOP-

1 Power unit

1 "O" parts box

4 telescoping arms

1 overhead beam

IN PARTS BOX-

1 71" hose

1 412" hose

4 arm pivot pins

4 spinups

20 anchor bolts

1 catalog

1 small parts bag

SMALL PARTS BAG-

1 1/16" wire

2 ferrules

1 6" pipe for piston

1 st thread T w/ O-ring

2 90 F.M. elbow

4 5/16" nylock nuts

4 5/16" 18 nuts

4 5/16"x 1" hex bolts

15 shims

2 3/4" plugs

Important notes

About your TP15KC lift...

Do not install this lift on any asphalt surface.

Do not install this unit on any surface other than concrete conforming to minimum specifications.

Do not install this lift over expansion joints or cracks. Check with building architect.

Do not install this lift on a second floor with a basement beneath without written authorization from building architect.

This lift is only as good as the floor you put it on. A good level floor is recommended for proper lift operation. Cement should be minimum of 4" thick and 3,000 psi tensile strength with steel or fiber mesh reinforcement.

The lift is intended to raise the entire body of the vehicle only. Do not attempt to lift only part of the vehicle. Improper use of this equipment could result in damage to the lift, yourself or other property.

The lift is intended to lift vehicles only. It is not designed to lift any person or equipment containing persons.

All persons using this equipment should be qualified, responsible persons and should follow the operation and safety guidelines set forth in this manual.

For specifications on concrete pads, please call for technical assistance.

Improper installation can cause damage or injury. Manufacturer will assume no liability for loss or damage of any kind, expressed or implied, resulting from improper installation or use of this product. Read the installation and operation manual in its entirety before attempting to install the lift.

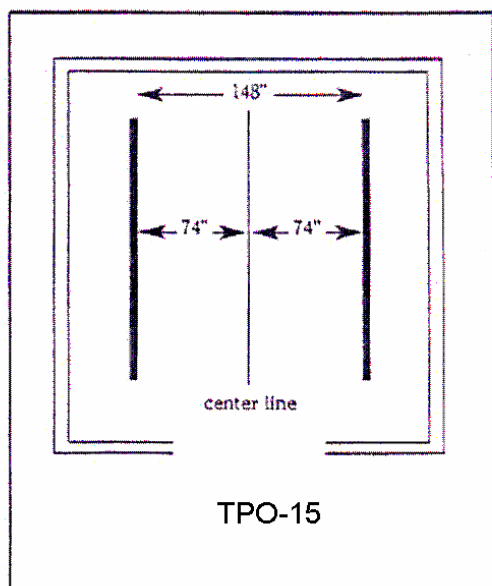

Installation Manual

TP15KC

Step 1: Measure lift area and check area for defects

The first step to any successful installation is to measure the bay for correct positioning of the lift. Measure the width of your doorway and divide it by two. This will give you the center of your doorway. Make a mark on the floor at the center of the doorway and measure from the side—wall to center mark. Note the distance and measure the same distance from the side wall at the front of the shop. Now snap a chalk line between the two marks—this is the center line for your lift.

Measure 74" from the center line to each side of the center line at front and rear of shop. Snap two more lines. These are your lift's outer dimensions (see figure 1).

NOTE: If you have less than 4" between the wall and your outer dimension, you should move the lift over to allow for at least 4" of space. Tuxedo Equipment recommends 12" between the wall and the outer dimension, but where that is not possible, 4" is acceptable.

Installation Manual

TP15KC

Step 1: continued

Find the length of the bay minus any work benches or other equipment and divide by two. For example, a 25' bay minus a 2' work bench equals a 23' bay. The center of the lift would be equal, at 11'6" from the garage door and the work bench. Draw a chalk line. Now measure 18" toward the garage door from the center line, this will be point "a". Measure 18" toward the work bench and mark this point "b". Measure diagonally from point "a" to the opposite side 152" and make a mark. This will be point "c". Measure from "b" in the same manner to find point "d". Mark a chalk line horizontally, from point "a" to point "d" and this will be your base line. (see figure 2)

NOTE: You should have 36" between points "a" and "b" just as with "c" and "d". If not, find the center and adjust as necessary.

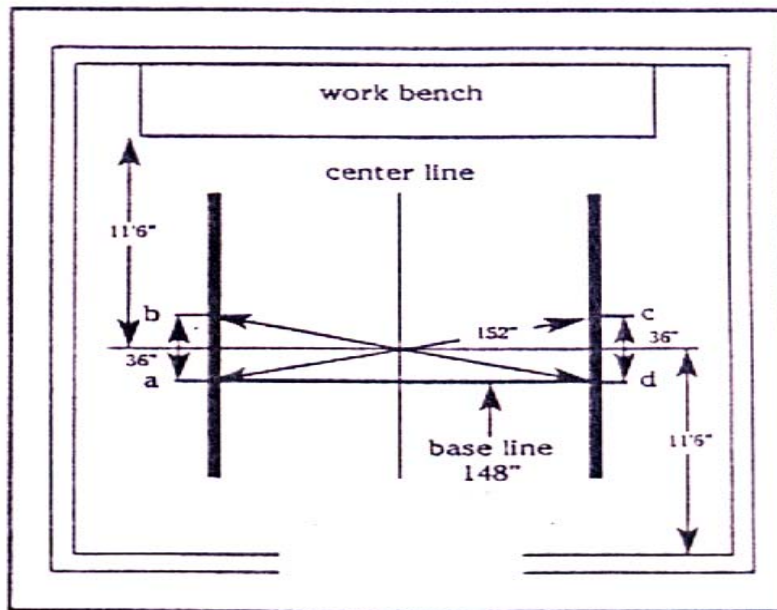

Installation Manual

TP15KC

Step 2: Cylinder Assembly

Install plug into 3/8" port using Teflon tape to insure leak-proof seal. With the column laying on the ground, slide the carriage toward the top far enough to place the cylinder into the column. When placing the cylinder, be sure the open port faces the cutout in the back of the column.

Assemble the nipple and elbow into the 3/8" port at the bottom of the cylinder though back of column, using Teflon thread tape to insure a good seal. Tighten firmly to avoid leaks. Be sure the elbow is pointing upward when tight (see figure 3).

While guiding the chain over the roller, release the safety lock on the carriage and slide the carriage back down to the bottom of the column. You are now ready to stand the column upright.

Repeat this process for the other side.

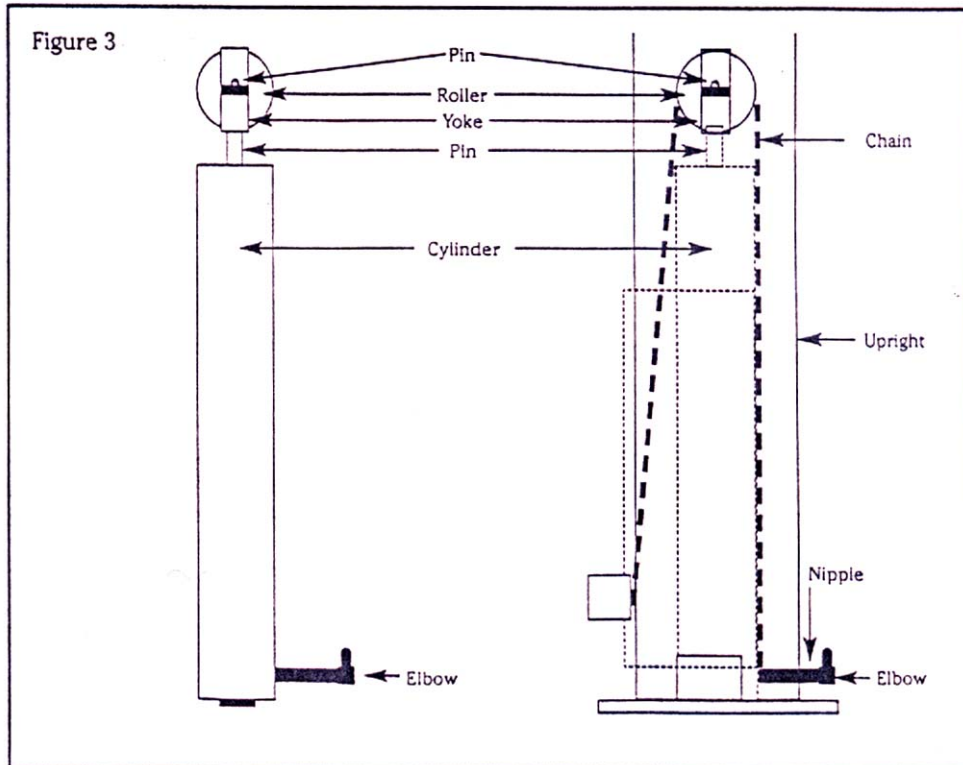

Installation Manual

TP15KC

Step 3: Position columns and uprights, level columns and install top beam.

Examine the area where your lift is going. Check for large cracks in the floor, expansion joints and for overhead obstructions. If either column is going to sit across or on top of an expansion joint, you may need to move the lift to a different location.

NOTE: Bolt holes in the base plate should be at least 4" from any expansion joint or large rack. You will need at least 13'4" of unobstructed ceiling height.

Position the columns as shown in figure 3. We recommend placing the power unit on the passenger side for ease of operation. Install the uprights so the threaded rods at the top face each other (the threaded rods should face the center line). Hand tighten for now. Using a four foot level, 3/4" flat washers and shims provided, shim the columns level, front-to-back and side-to-side. Recheck the uprights to see that they are facing each other. If not, rotate the columns as needed and be sure to keep the base plates on the line.

You are now ready to install the top beam. Carry the beam to the top and hook each side to the top of an upright, guiding the bolt into the slot. Hand tighten nuts on the two bolts.

Check the columns again to see if they are level and on the base line. You may need to hammer the columns using a rubber mallet, toward or away from center in order to get them level. Be sure to keep the columns even on the base line. The outer dimensions are not as important at this point. Check top for space between the upright and top beam. You should have less than 1/4" between. If you have more, tighten nuts at top beam on both side and re-level the columns.

NOTE: Double check everything now—next step is permanent!

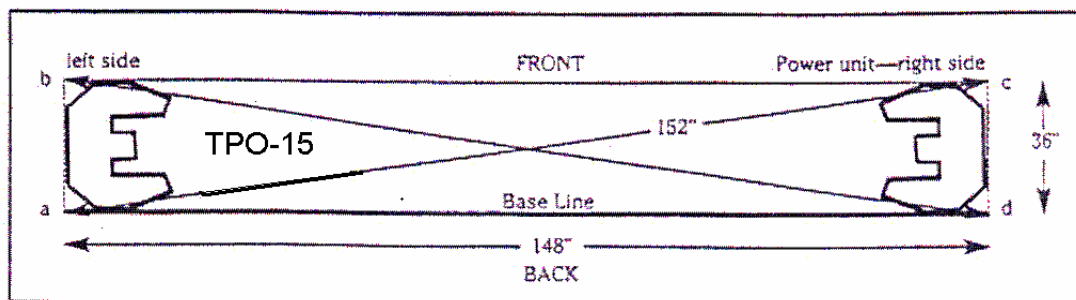

Installation Manual

TP15KC

Step 4: Install anchor bolts and re-level columns

You will need a rotary hammer with a 3/4" carbide Hammer Drill bit (most rental outlets carry them). Do not use a regular drill and bit!

Your floor must be a minimum of 5" thick and 3000 psi concrete or better. Using your rotary hammer, drill twenty 3/4" hole. Drill through the floor and hammer the anchor bolts in half-way (install the nut and flat washer on the bolt before placing them into the hole).

NOTE: Be careful not to move the columns when drilling. One way to avoid this is to drill the holes and place the bolts one-at-a-time and save the inside hole for last.

Recheck the level of each column and place shims around or beside each bolt and wherever there is space. Hammer the anchor bolts all the way down. Using a torque wrench, tighten the anchor bolts to 120 pounds of torque. Recheck the level of the columns.

If the columns are off, loosen the anchors and use a pry bar to tilt the columns and shim as needed. Retighten and check again. Now tighten the bolts on the uprights. With all bolts tight and the columns as close to level as you can get, you will have a good solid installation and years of trouble-free service.

Step 5: Install and adjust cables

Using two people, a fork-lift or a shop crane, lift each carriage to the second or third lock. Allow each carriage to rest on the locks and measure each side to be sure they are at the same height. Unwrap the two large cables and separate them. Remove the four 3/4" lock nuts and four 3/4" thin flat washers. Place nuts and two flat washers on each carriage so they are easy to get at.

With your back to the door and standing between the posts, turn to your left. This will be called the "left" column. The side closest to the front wall will be the front end and the side closest to the door will be called the back.

Grab one cable end and run it over the left front pulley on the upright, down through the slot in the upright and through the hole in the corner of the carriage. Drop the end down on the floor, grab the end and put a flat washer and nut on it. Tighten the nut about 2/3 of the way on the rod. Grab the other end of the same cable and run it over the top of the front right pulley, down through the slot and straight down inside the carriage to the floor. Run the cable under the pulley on the bottom, up through the carriage and into the hole in the corner of the carriage. Pull the end through the hole. Make sure the other rod is now sitting in the hole in the other carriage. If you see less than 2" of rod sticking up, you can install the flat washer and nut, otherwise go back to the left side and tighten the nut more to take up the slack. Install the other cable in the same fashion, starting from the right side and running it over the back pulleys.

With both cables in place, you are ready to adjust. Start on the left side. With a pair of vice grips, grab the bottom of the rod whose threads are pointing up. Place an 11/16" deep socket on the nut and tighten it until the opposite side raises 1/4". Tighten the other side the same way until it comes back down 1/4" and then give it one full turn. Both cables should now have the same tension.

NOTE: Do not over tighten cables. This will cause lift to lose carrying capacity and could damage the components.

Installation Manual

TP15KC

Step 6: Install power unit, hoses and cut-off cable

Unpack the power unit from the box and remove the wood shipping board. Inspect the unit for damage before continuing. Remove the plastic cap from the 3/8" port on the side of the pump and install the "T" fitting found in the parts box. Screw in the "T" until the O-ring touches the pump and the ends are facing the top of the motor and the bottom of the tank. Then use an 11/16" wrench to tighten the locking nut and assure a good seal. Next use a screwdriver to pry off the 1" plastic cap from the tank. Place a funnel in the hole and fill the tank with 3.5 gallons of AW32 hydraulic oil (NAPA part # 760 is recommended). Locate the four 5/16"x 1" bolts, four nuts and four lock nuts in the parts box. Place the four bolts in the

four holes on the mounting plate on the column, then place the four nuts hand-tight onto the four bolts. Hang the power unit on the four bolts and put the four lock nuts in place to hold them. Tighten the four nuts first, then the lock nuts.

Unpack the long hose and connect one end to the fitting at the back of the left column. Run the hose up and over the top along the top beam and down through the other side to the top of the "T" fitting. You may wish to attach the hose to the top beam with wire ties or clamps. Attach the short hose to the bottom of the "T" and then to the bottom of the right column.

Check all fittings to be sure they are tight, to avoid leaks!

Attach the 1/16" cable to the flat washer at the top of the left side upright using the small aluminum ferrules. Loop the cable through the ferrule, then through the washer and back through the ferrule. Crimp the ferrule to hold the cable. Pass the cable through the washer on the right side and down through the empty bolt hole in the middle of the upright. Loop the cable through the eye on the cut off switch box, secure with ferrule. Make it as tight as you can without tripping the cutoff switch.

Step 7: Install arms

Place the four arms onto the carriage torsion tubes. Line up the holes and secure with steel swivel pins.

Step 8: Install spinup pads and check height adapters

Screw the four spinup pads onto the arms and test to see if they screw up and down smoothly in the arm nut. Slip the four truck adapters over the pads to make sure they all fit. If you have one that doesn't fit, call the service line for a replacement.

Step 9: Electrical Hook-up

The electrical hook-up should be done by a certified electrician. The power unit requires 220v 30 amp circuit breaker. It is recommended that you install a means of shutting down the power in close proximity to the power unit (a twist lock plug hung from the motor will be sufficient). The motor is factory pre-wired for proper power and rotation.

Installation Manual

TP15KC

Step 10: Test and adjust Lift

With the power properly hooked up and turned on, push the silver button to raise the lift (the cylinders will take a little while to catch up with the chain, then the lift will begin to rise). Raise the lift as high as it will go. Pull the key ring located near the bottom of each carriage to release the safety locks. Locate the lowering handle on the power unit. Pull and hold handle until the lift goes all the way down to the floor. Continue holding handle for at least 30 seconds to allow any air to escape from the hydraulic system. Once the lift is fully down, it's a good idea to have someone push down on the cylinders while you hold out the lowering handle. This will force out any additional air pockets. You only need do this once.

Run the lift all the way up and down two more times. While running the lift, listen to the safeties clicking. Each side should click within one second of each other or simultaneously.

If they are not clicking together, you can adjust the cables to compensate by either tightening the side that is clicking first or loosening the side that is clicking last. Remember not to over-tighten cables—they should be firm, much like a banjo string.

If one or both safeties are not clicking at all, you will need to adjust the safety locks. This can be done by raising the lift until you see a bolt attached to the safety latch through the hole in the side of column. You will also see a bolt attached to the safety latch. Give the bolt one turn clockwise and run the lift up and down once again. Continue this process until the safety starts to work. If the safeties are locking as you lower the lift, you will need to turn the bolt counter-clockwise in the same manner.

Installation Manual

TP15KC

Operation: Learn proper operation and recheck lift components

On model TP15KC swing front arms to the front and the rear arms to the rear. Once arms are in position, pull a car into the bay. A general rule of thumb is to stop the car with the center of the wheel base even with the center of the columns.

Swing the four arms under the vehicle and position the pads under the appropriate lifting spots. (If you are not sure of the proper lifting points, you should check the vehicle's service manual or contact the vehicle manufacturer.) Adjust the screw pads so they all hit their lift points at the same time. This will allow the car to be level when rising.

With the pads in their proper locations and no obstructions around the lift or vehicle, you may now press the button on the power unit to raise the vehicle.

Raise the vehicle so that the tires are only 6" off the ground. Walk to the back of the vehicle and push up and down on the bumper. The vehicle will rock, but should not at any time lose contact with the pads. If the vehicle is bouncing off the pads or feels at all unstable, you should lower it back to the ground and reposition the pads to balance the load. Repeat this process until the vehicle is completely stable.

When the vehicle is stable, you may raise the lift all the way to the top. Listen to safeties and adjust if necessary.

The proper operation of the lift requires that any time you raise a vehicle to work on it, you must lower the lift into the safety locks. This is done by raising the vehicle to the desired height and lowering the lift until it stops on the next available lock. To lower vehicle, you must first raise the lift 1/2", release the safeties by pulling the key ring located near the bottom of each carriage, then pull the lowering handle. If you wish to lower the lift halfway and resume working on the vehicle, you must lower the vehicle 6" below the desired height, raise the lift again to engage the locks and then lower the lift onto the locks.

Never work under or near the lift without the locks engaged—the pump is not intended to be a load-holding device. Not using the locks will result in premature failure of the cylinders, pump and cables—and can cause serious property damage or personal injury. Failure to heed this warning will result in immediate termination of your warranty.

Installation Manual

TP15KC

Maintenance

Maintenance is the key to smooth, safe operation and longer life of your lift. Follow these guidelines on a regular basis to keep your lift running efficiently.

1. Your lift is only as good as the floor it is mounted on. Cracked or shallow concrete should be watched at all times. Although your floor may be thick enough according to manufacturers specs, cracks and shallow spots can cause bolts to loosen and pull out of the floor. All anchor bolts should be checked and retightened at least once a month. Loose anchor bolts and weak cement are the number one cause of lift failure!

2. Grease all the corners of the columns where the carriages run up and down. The grease will do more good if you periodically clean off the old grease to get rid of any grit. A thin film of grease works better than thick blobs.

3. You should oil the chains on your lift at least twice a year to keep them from rusting and freezing up. Thirty-weight motor oil or motorcycle chain lube will be sufficient.

4. All of the pulleys on your lift should be sprayed with a light oil such as WD-40 or similar lubricant, two to three times a year.

5. You should check for cracked or warped parts regularly and re-tighten any loose bolts.

6. Cables are an important part of your lift. They keep both sides running equal to the other, allowing the safeties to catch together. If one side of your lift is running ahead of the other, most likely it is time to adjust your cables. Follow this simple procedure:

- a. Raise the lift so the top of the carriage clears the chain and pulley.
- b. Notice the threaded rod and nut which stick out through the top of each carriage. These are your adjusting nuts.
- c. You will tighten the nut on the side that is lifting ahead of the other by holding the bottom of the threaded rod with a pair of vice-grips and turning the nut with a suitable wrench or socket.
- d. Run the lift up and down and determine if you need further adjustment. If so, repeat steps a through c.

If at any time you're not sure of the safe operation of the lift, discontinue using it and call our technical support line for assistance.

Installation Manual

TP15KC

Troubleshooting Guide

PROBLEM	POSSIBLE CAUSE	SOLUTION
Motor won't run	<ol style="list-style-type: none"> 1. Fuse or circuit breaker. 2. Incorrect voltage to motor. 3. Wiring connections. 4. Burned out micro switch. 5. Burned out motor windings. 	<ol style="list-style-type: none"> 1. Replace blown fuse or reset circuit breaker. 2. Supply correct voltage to motor. 3. Check and repair or insulate all connections. 4. Replace micro switch. 5. Replace motor.
Motor runs but	<ol style="list-style-type: none"> 1. Motor runs in reverse direction. 	<ol style="list-style-type: none"> 1. Change motor rotation by reversing

won't raise lift	<ol style="list-style-type: none"> 2. Open lowering valve. 3. Pump is sucking air. 4. Suction tube is off of pump. 5. Low oil level. 	<ol style="list-style-type: none"> motor. 2. Repair or replace lowering valve. 3. Tighten all suction line fittings. 4. Replace suction tube. 5. Top-off tank.
Motor runs, raise lift, but not vehicle	<ol style="list-style-type: none"> 1. Motor is running on low voltage. 2. Debris in lowering valve. 3. Improper relief valve adjustment. 4. Overloading of lift. 	<ol style="list-style-type: none"> 1. Supply correct voltage to motor. 2. Clean lowering valve. 3. Replace Relief Valve cartridge. 4. Check vehicle weight or balance load properly.
Lift settles down slowly	<ol style="list-style-type: none"> 1. Debris in check valve. 2. Debris in lowering valve. 3. External oil leaks. 	<ol style="list-style-type: none"> 1. Clean check valve. 2. Clean lowering valve. 3. Check for and repair any leaks.
Lift goes up unevenly	<ol style="list-style-type: none"> 1. Equalizer cables not properly adjusted. 2. Lift installed on uneven floor. 	<ol style="list-style-type: none"> 1. Adjust cables according to manual. 2. Shim column(not more than 1/2") or adjust spin-up pads to compensate.
Anchor bolts won't stay tight or are pulling out of floor	<ol style="list-style-type: none"> 1. Cement thickness/strength insufficient. 2. Holes are too big for bolts. 	<ol style="list-style-type: none"> 1. Remove bad cement, pour new pad for lift per specs in manual. 2. Relocate lift using the proper size drill bit, or pour anchoring cement into holes to secure bolts.
Safety latches don't work	<ol style="list-style-type: none"> 1. Safety not adjusted properly. 2. Safety spring not connected. 3. Flat washer bent too far, squeezing release cable. 4. Safety latch is rusted or frozen. 	<ol style="list-style-type: none"> 1. Raise lift until safety adjusting bolt appears in window, adjust as needed. 2. Reconnect safety spring. 3. Blend flat washer way from release cable until it moves freely. 4. Spray penetrating oil on latch and work the latch until it moves freely.
Cylinder whines or chatters	<ol style="list-style-type: none"> 1. Dry or tight seal. 	<ol style="list-style-type: none"> 1. Remove cylinder vent and spray Dura-lube or Teflon spray lube into cylinder.
Oil squirts out of cylinder vent	<ol style="list-style-type: none"> 1. Bad seal. 	<ol style="list-style-type: none"> 1. Replace seal or cylinder.

ADJUSTABLE ARM LOCK INSTALLATION INSTRUCTIONS

INSTALL ROD ASSEMBLY AS SHOWN

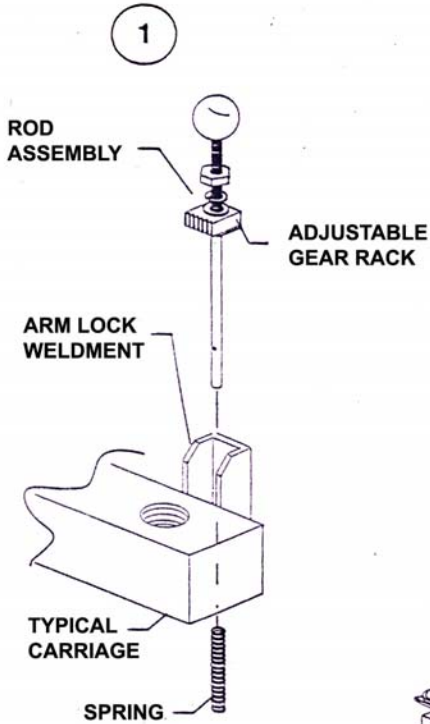

INSTALL COTTER PIN AS SHOWN TO ENSURE SPRING STAYS INPLACE.

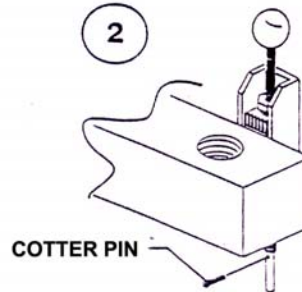

ADJUST ROD HEIGHT WHEN CARRIAGE IS IN REST POSITION

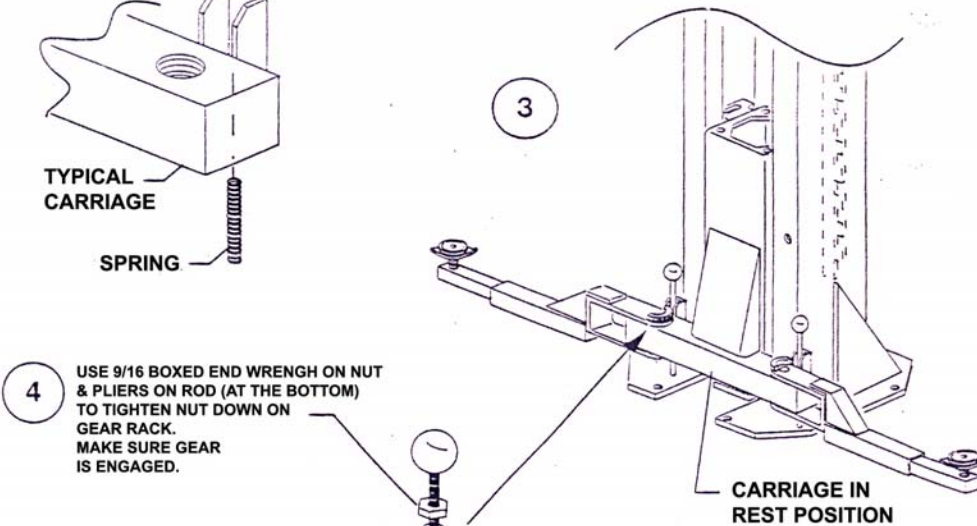

4 USE 9/16 BOXED END WRENCH ON NUT & PLIERS ON ROD (AT THE BOTTOM) TO TIGHTEN NUT DOWN ON GEAR RACK. MAKE SURE GEAR IS ENGAGED.

SAFETY IMPORTANCE

ADJUST GEAR RACK WITH SWING ARM INSTALLED BEFORE OPERATION USE. IF NOT DONE PROPER MAY RESULT IN SERIES INJURY OR DEATH

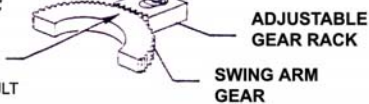

MAINTENANCE SCHEDULE

The following periodic maintenance is the suggested minimum requirements and minimum intervals: accumulated hours or monthly period, which ever comes first. If you hear a noise

or see any indication of possible failure cease operation immediately and inspect, correct and/or replace parts as required.

Following these maintenance procedures is the key to prolonging the useful life of your lift.

IF AT ANY TIME YOU'RE NOT SURE OF THE SAFE OPERATION OF THE LIFT, DISCONTINUE USING IT AND CALL YOUR DISTRIBUTOR FOR ASSISTANCE.

WARNING OSHA AND ANSI REQUIRE USERS TO INSPECT LIFTING EQUIPMENT AT THE START OF EVERY SHIFT. THESE AND OTHER PERIODIC INSPECTIONS ARE THE RESPONSIBILITY OF THE USER.

DAILY PRE-OPERATION CHECK

The user should at least perform the following checks daily.

Daily check of Safety Latch System is very important — the discovery of device failure before needed could save you from expensive property damage, lost production time, serious personal injury and even death.

Check Safety Latches for free movement and full engagement with rack.

Check hydraulic connections, and hoses for leakage.

Check Snap rings all rollers and sheaves.

Check Bolts, Nuts, and Screws and tighten.

Check Wiring and Switches for damage.

Keep base plate free of dirt, grease and any other corrosive substances.

Check for stress cracks in the concrete floor near the anchor bolts which, if present, could cause the anchor bolts to loosen and pull out of the floor.

Check Cables: Cables keep both sides of the lift running equally allowing the safeties to catch together. If one side of your lift is running ahead of the other, most likely it is time to adjust your cables. Follow this simple procedure:

1. Raise the lift so the top of the carriage clears the pulley at the bottom of the post.
2. Notice the threaded rod and nut that sticks out through the top of each carriage. These are your adjusting nuts.
3. Tighten the nut on the side that is lifting ahead of the other by holding to bottom of the threaded cable end with vice-grips and turning the nut with a suitable wrench.
4. Run the lift up and down and see if it needs more adjustment. If so, repeat steps 1 through 3.

Check floor for stress cracks near anchor bolts.